

hydride, suspended in ethers, may be used in place of lithium aluminum hydride, but the latter in general reacts more rapidly and at lower temperatures to give better yields.

3. In the one instance investigated, sodium hydride did not undergo the analogous reaction un-

less aluminum chloride was added to the reaction mixture.

4. Physical and chemical properties of six new organosilanes and two new methyl stannanes are briefly described.

CHICAGO 37, ILLINOIS

RECEIVED MAY 12, 1947

[CONTRIBUTION FROM THE DEPARTMENT OF CHEMISTRY, MASSACHUSETTS INSTITUTE OF TECHNOLOGY]

## Anhydrous Lower Bromides of Hafnium

BY WALTER C. SCHUMB AND CLARENCE K. MOREHOUSE

Although the remarkably close resemblance in properties of hafnium to zirconium is commonly recognized, the existence of lower valence halides of hafnium, analogous to the tri- and divalent halides of zirconium, seems not to have been established. Employing procedures similar to those used by R. C. Young<sup>1</sup> in preparing zirconium tribromide and dibromide, we have been able to demonstrate that hafnium forms analogous lower valence compounds with closely similar properties.

Hafnium dioxide obtained from a commercial laboratory was found to contain 99.9% of combined hafnium and zirconium oxides by the selenious acid method,<sup>2</sup> and the hafnium to zirconium ratio in the mixed oxides was determined by the procedure of Claassen,<sup>3</sup> later modified by Schumb and Pittman.<sup>4</sup> In this manner the hafnium oxide was found to contain 97.2% hafnium dioxide and the rest essentially zirconium dioxide. A qualitative spectroscopic analysis confirmed these conclusions.

### Experimental

**Preparation of Hafnium Tetrabromide.**—Five-gram portions of the hafnium dioxide were converted into the tetrabromide by the method described by Hönlgschmid, Zintl and Gonzalez,<sup>5</sup> with slight modifications, in which the oxide, in an intimate mixture with 15 g. of dry sugar charcoal, was heated in a graphite boat in a Pyrex apparatus at 700–800° in an atmosphere of pure nitrogen saturated with bromine vapor. The product was thrice re-sublimed and sealed off in a glass tube in a dry nitrogen atmosphere. Eleven grams of the tetrabromide was obtained from each five grams of oxide; the purity of the product was not less than 95.5% hafnium tetrabromide. It was a white, crystalline solid, which sublimed readily at 400° at ordinary pressure, or at 280° at 1 mm. pressure. It is estimated that not over 25° separate the sublimation temperatures of hafnium and zirconium tetrabromides.

**Reduction of the Tetrabromide.**—The sublimed, anhydrous hafnium tetrabromide was subsequently reduced to the tribromide in the apparatus shown in the accompanying figure, which consisted essentially of a 19 mm. "hot-cold" tube of Vycor glass, sealed at each end to standard taper quartz joints and thence connected to the rest of the

apparatus, which was made of Pyrex glass. A closely-wound aluminum coil (99.9% aluminum), 5-cm. long, was placed with one end 3 cm. from the end of the cold element of the "hot-cold" tube. The sample of hafnium tetrabromide, introduced through joint C, with as little access to the air as possible, was shaken down to a position between G and S. When the apparatus was filled with dry, oxygen-free hydrogen, the tetrabromide was slowly sublimed, in the hydrogen atmosphere, through a filter plug, S, of glass wool, and thus over the aluminum coil, T, which had been heated to 600°, as indicated by a chromel-alumel thermocouple placed outside the Vycor tube in the furnace, U.

A blue-black mass collected on the end of the "cold finger," consisting of aluminum bromide and hafnium tri- and tetra-bromides. Twenty to thirty minutes were required for this operation, during which the temperature of the reaction tube remained at 600–650°, or just below the melting point of the aluminum wire. After the volatilization of the tetrabromide had been completed, the furnace was cooled to room temperature and pure, dry nitrogen was substituted for the hydrogen in the apparatus.

The rest of the procedure followed closely in principle that previously described in the preparation of zirconium tribromide: the transfer of the products from the "cold finger" to tube, E, through constriction, J; sealing at J; complete sublimation *in vacuo* of aluminum bromide and unchanged hafnium tetrabromide over a period of twelve to fifteen hours at a maximum temperature of 290°; finally transfer of the blue-black tribromide to the small side-tube, K, and sealing off in an atmosphere of nitrogen.

An analysis of a sample of the product thus obtained gave 42.02% Hf; 60.54% Br; corresponding to an atomic ratio of Br: Hf = 3.2.

In the preparation of this substance, and in its properties, so far as they were examined, the phenomena observed closely paralleled those reported for zirconium tribromide. The blue-black solid reacted immediately with water with evolution of hydrogen; ammonium hydroxide added to this solution precipitated hydrous hafnium dioxide.

A sample of the tribromide contained in an evacuated 8-mm. Pyrex tube, 16 cm. long, was heated very gradually in an electric sleeve furnace so as to observe its decomposition at elevated temperatures. It is well known that zirconium tribromide on heating disproportionates into di- and tetrabromide

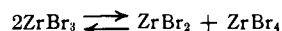

the white tetrabromide sublimes leaving the non-volatile, black dibromide. Similarly, at higher temperatures the dibromide decomposes, forming zirconium metal and the tetrabromide

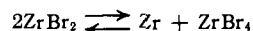

In precisely analogous manner, the sample of hafnium tribromide, heated *in vacuo* to slightly above 300° gave a deposit of white tetrabromide at the cold end of the reaction tube and the color of the residue became jet black. The

(1) R. C. Young, *THIS JOURNAL*, **53**, 2148 (1931).

(2) Simpson with Schumb, *ibid.*, **53**, 921 (1931).

(3) Claassen, *Z. anal. Chem.*, **117**, 252 (1939).

(4) Schumb and Pittman, *Ind. Eng. Chem., Anal. Ed.*, **14**, 512 (1942).

(5) Hönlgschmid, Zintl and Gonzalez, *Z. anorg. allgem. Chem.*, **139**, 293 (1924); **140**, 335 (1924).

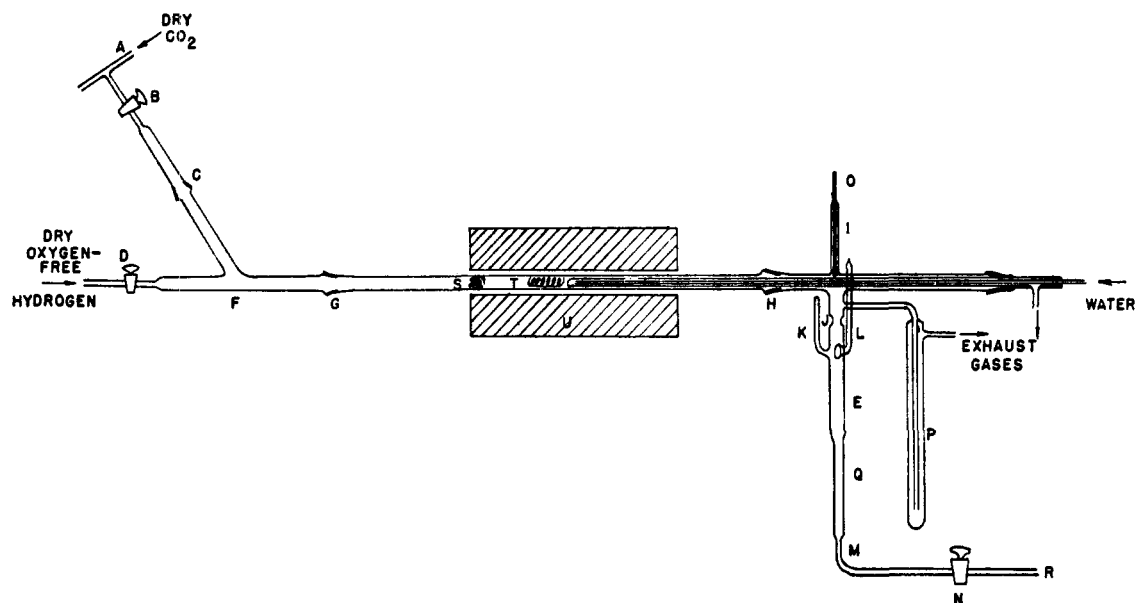
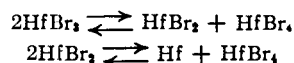

Fig. 1.—Preparation of hafnium tribromide: S, Pyrex glass wool plug; T, aluminum metal wire; U, electric furnace.

temperature of the heated end of the tube was maintained at 350–360° for twelve hours, after which time further accumulation of tetrabromide ceased. When the temperature was now slowly raised above 360° no further white deposit occurred until a temperature above 400° was reached whereupon a new accumulation was observed which collected at an increasing rate as the temperature was raised to 500°.

Although these observations are only qualitative, it seems clearly indicated that the reactions



occurred at temperatures somewhat above 300 and 400°, respectively.

When a tube containing a sample of the jet black solid, believed to be the dibromide,  $\text{HfBr}_2$ , was broken under water, a vigorous reaction was noted, with evolution of hydrogen—a result which is again similar to that shown by zirconium dibromide.

### Summary

Anhydrous hafnium tetrabromide of purity greater than 95% hafnium tetrabromide, was prepared from the dioxide, which had been shown by

analysis to consist of 97.2% hafnium dioxide, the rest being essentially zirconium dioxide. The tetrabromide was reduced to tribromide by a method closely similar to that previously used for the preparation of zirconium tribromide—heating of the vapors, mixed with hydrogen, in the presence of pure aluminum, at 600–650° in a “hot-cold” tube.

The blue-black solid obtained closely resembled zirconium tribromide in its physical and chemical properties. On heating *in vacuo* to over 300° it disproportionates into jet black, non-volatile dibromide and the tetrabromide. At a still higher temperature, well above 400°, the black dibromide decomposes into metallic hafnium and the tetrabromide.

The lower valence bromides of hafnium, like those of zirconium, react with water with liberation of hydrogen and oxidation of hafnium to the tetravalent state.

CAMBRIDGE, MASSACHUSETTS RECEIVED APRIL 18, 1947